

PHILIPS 650A THREE-BAND FIVE

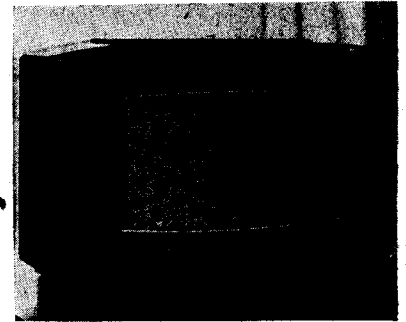

Although a "five," the 650A has a signal amplifier stage. With orthodox manual tuning it incorporates a cathode-ray indicator.

CIRCUIT.—Aerial input to the grid of the H.F. amplifier V1, an H.F. pentode, is via transformer coils. The A.V.C. potentials are applied direct to the grid instead of via the tuning coils, a grid isolating condenser being used.

H.F. transformers provide the coupling to the signal grid of the EK2 frequency changer, V2. Series grid resistances are included to the signal and oscillator grids and the reaction windings are fed direct.

An iron core I.F. transformer of the fixed condenser type, tuned to 470 kcs., effects the coupling between V2 and V3, an EF9 I.F. amplifier. V3 becomes an L.F. amplifier for gram. work, the screen of the valve being used as the anode electrode of a triode, the potentials being fed to the volume control by R18, the load, and C37, the coupling condenser.

V3 is coupled by a further I.F. transformer to the demodulating diode of V4, an ELB1 double diode output pentode. Both primary and secondary of the I.F. transformer are tapped down. The other diode provides a D.C. potential controlling V1 and V2 via the A.V.C. circuit.

The rectified impulses derived from the demodulating diode are taken via a tone compensated manual volume control to the control grid of the pentode section of V4. A pentode compensating condenser is connected across the primary of the speaker matching transformer, and also a tone control circuit, C42, R32 and R33. The demodulated impulses also feed the EM1 visual tuning indicator.

Mains equipment consists of a full-wave

rectifying valve, a mains transformer, electrolytic smoothing condensers, and a separate smoothing choke.

Chassis Removal.—Remove back of cabinet and the three grub-screw fixed control knobs. Loosen the grub screw securing the extension shaft of the tone control at side of cabinet and unsolder the wire to the earthing tag of the metal screen on the floor of the cabinet.

Remove the eight bolts from the four metal brackets disposed two each side of the chassis on the front (inside) of the cabinet. The four bolts securing the wavelength pointer travel assembly should be removed from the roof of the cabinet, taking care not to injure the Bowden cables or to scratch the W.L. scale.

The chassis, complete with speaker assembly, can then be withdrawn from the cabinet.

Special Notes.—The mains adjustment consists of a bakelite disc, inscribed with voltage values and mounted on an insulat-

ing panel at the rear of the chassis deck. To adjust, the disc should be pulled out slightly until it is free to turn and then rotated until the desired voltage is at the top of the disc.

The mains input leads are taken via a safety device to the connecting plugs on the panel at the rear of the chassis. The safety device must be removed from the back if operation with the back removed is desired.

A lever-operated Q.M.B. gram-radio switch is near the pick-up sockets.

Another pair of sockets enables an extension speaker of 7 ohms impedance to be operated.

The visual tuning indicator valveholder, secured by a milled nut, must be removed before the Mullard type EM1 indicator can be removed. The anode feed resistance R26 is connected across the holder.

The single dial and pointer illuminating lamp is mounted on a bracket on the chassis deck. A reflector strip is used to evenly distribute the light over the wave-

VALVE READINGS

| No signal. | | Volume maximum. | | M.W. min. cap | |
|------------|------------------|-----------------|--------|---------------|--|
| V. | Type. | Electrode. | Volts. | Ma. | |
| 1 | All Mullard. EF8 | Anode | 265 | 4.3 | |
| | | Screen | 190 | .1 | |
| 2 | EK2 | Anode | 190 | 2.2 | |
| | | Osc. anode | 180 | 1.3 | |
| | | Screen | 90 | 3.5 | |
| 3 | EF9 | Anode | 260 | 6.4 | |
| | | Screen | 90 | .2 | |
| 4 | ELB1 | Anode | 235 | 34 | |
| | | Screen | 260 | 5.5 | |
| 5 | Phillips AZ1 | Heater | 290 | — | |

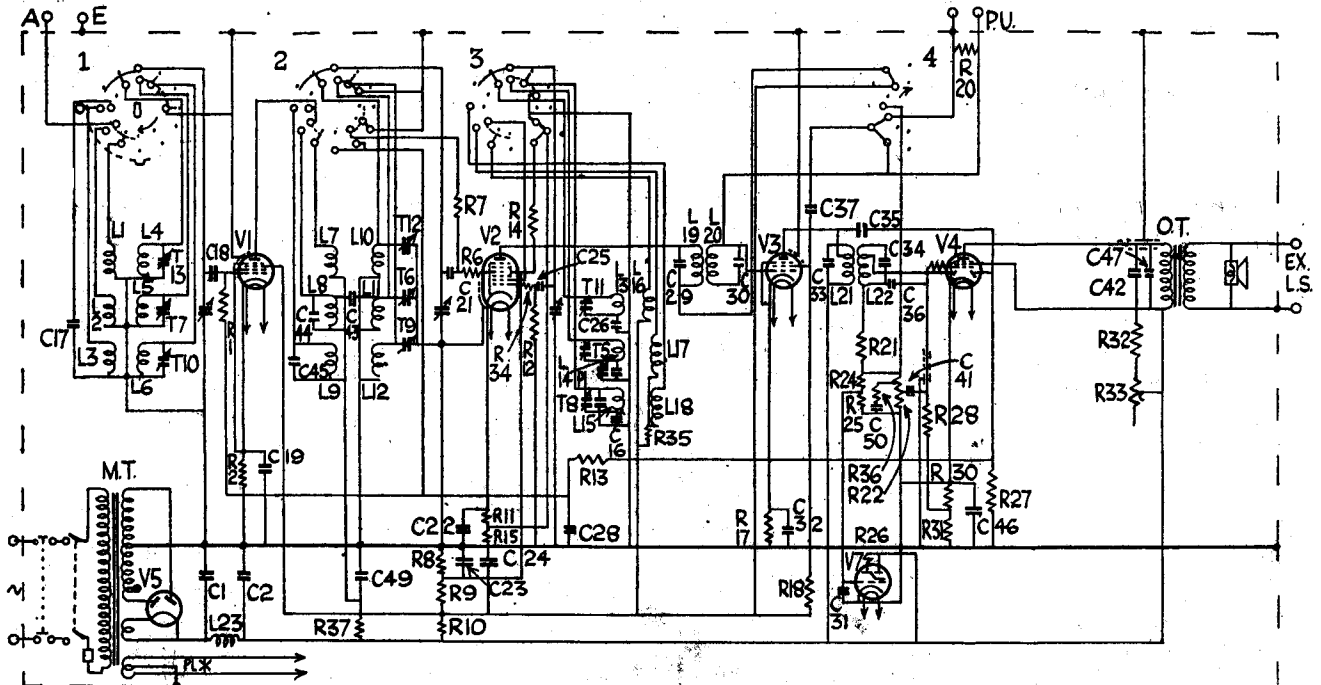

A combined diode and output pentode saves a stage and means that while nominally a "five," the 650A is virtually a "six." The I.F. transformers are permeability trimmed.

length scale. The bulb is a Philips type 8091 D-00, and has an M.E.S. base.

R29, the grid stopper resistance of V4, is mounted on an insulating strip on the top grid connecting cap, and R6 on V2, C29, C30, C33 and C34 are inside the corresponding I.F. transformer cans. C43 is inside the anode coils can.

Alignment Notes

I.F. Circuits.—Set wavechange switch to M.W., turn volume to maximum, tune control to high position and earth the receiver. Short-circuit C28, connect a service oscillator between top grid cap of V2 (via a .32 mfd. fixed condenser) and chassis. Connect an output meter in usual manner. Turn gang to maximum.

Shunt I.F.T.2 primary with .00008 condenser, tune service oscillator to 470 kcs. and adjust T1 for maximum.

Remove .00008 condenser, connect across I.F.T.2 sec. and adjust T2 for maximum. Remove .00008 condenser, connect across I.F.T.1 prim. and adjust T3 for maximum.

Remove .00008 condenser, connect across I.F.T.1 sec. and adjust T4 for maximum.

Remove shunt condenser and short circuit from C.28.

Signal Circuits.—Turn quality switch to maximum (clockwise position 2). Fit 15 degrees jig (available from Philips) and set the gang to it (maximum capacity position). Connect the service oscillator to the A. and E. sockets via a dummy aerial, only feeding sufficient input to obtain definite peaks in the output meter and progressively reducing the output as the circuits come into line; P1 and P2 are of the unorthodox Philips construction.

Medium Waves.—Tune service oscillator to 1,442 kcs. and adjust T5, T6 and T7 in that order for maximum and then remove 15 degrees jig.

Short-circuit C25 to chassis, tune oscillator to 546 kcs., connect a G.M.2404 or aperiodic amplifier to anode of V2 and connect output meter to the aperiodic amplifier.

Tune in the 546 kcs. signal on receiver, to resonance in output meter, disconnect amplifier, reconnect output meter to receiver, remove short

WINDINGS (D.C. Resistances)

| L. | Ohms. | Range | Where Measured. |
|-----------------|-----------|-------|----------------------------|
| 1 | 2.4 | S.W. | Aerial socket and chassis. |
| 2 | 25.1 | M.W. | Aerial socket and chassis. |
| 3 | 105 | L.W. | Aerial socket and chassis. |
| 4 | .1 | S.W. | C18 and chassis. |
| 5 | 4.9 | M.W. | C18 and chassis. |
| 6 | 45 | L.W. | C18 and chassis. |
| 7 | 3 | S.W. | Anode V1 and C49. |
| 8 | 276 | M.W. | Anode V1 and C49. |
| 9 | 486 | L.W. | Anode V1 and C49. |
| 10 | Very low. | S.W. | H.F. gang and chassis. |
| 11 | 4.9 | M.W. | H.F. gang and chassis. |
| 12 | 441 | L.W. | H.F. gang and chassis. |
| 13 | Very low. | S.W. | Osc. gang and C26. |
| 14 | 8.8 | M.W. | Osc. gang and P1. |
| 15 | 18 | L.W. | Osc. gang and P2. |
| 16 | 1.2 | S.W. | Osc. anode and C24. |
| 17 | 3 | M.W. | Osc. anode and R35. |
| 18 | 4.3 | L.W. | Osc. anode and R35. |
| 19 | 9 | — | Anode V2 and C24. |
| 20 | 8 | — | Top grid V3 and tag. |
| 21 | 4.5 | — | Anode V3 and C2. |
| 22 | 3.2 | — | Diode V4 and R21. |
| 23 | 380 | — | C1 and C2. |
| OT. prim. | 640 | — | Tags. |
| M.T. prim. | 52 | — | Mains plug. |
| Total H.T. sec. | 420 | — | Anode pins V5. |

Philips 650A on Test

MODEL 650A.—A.C. mains operation, 100-260 volts, 50-100 cycles. Price 10 gns.

DESCRIPTION.—Four-valve, plus rectifier, three-band superhet using the new E type valves.

FEATURES.—Full-vision scale, calibrated in metres and station names, traversed by an illuminated pointer. Controls for tuning, combined volume and master switch, wave selection and tone. Visual tuning indicator. Sockets for extension speaker. Gram-radio switch at rear of chassis.

LOADING.—55 watts.

Sensitivity and Selectivity

SHORT WAVES (16.7-51 metres).—Excellent gain and selectivity with very easily handling and a good background.

MEDIUM WAVES (200-585 metres).—Well maintained gain with excellent selectivity and local stations spread on adjacent channels only. Clean background.

LONG WAVES (725-2,000 metres).—Similar performance to medium waves. Slight side splash on Deutschlandsender.

Acoustic Output

Very good, well balanced tone, with excellent low-note radiation and crisp clean attack. Speech practically without colouration and generally pleasing balance on orchestral music. Ample volume for an ordinary room.

from C25 and, without altering the receiver tuning control, adjust P1 for maximum.

Realign T5, T6 and T7 on a 1,442 kcs. signal with gang condenser in jig.

Long Waves.—With gang condenser set to jig, tune oscillator to 405 kcs., and adjust T8, T9 and T10 for maximum. Remove jig. Short-circuit C25 to chassis, tune oscillator to 160 kcs., reconnect aperiodic amplifier and output meter to amplifier.

Tune in 160 kcs., signal on receiver to resonance in output meter, disconnect amplifier, reconnect output meter to receiver, remove short from C25 and, without altering the tuning control, adjust P2 for maximum.

Realign T8, T9 and T10 on a 405 kcs. signal. **Short Waves.**—With gang set to jig, tune a service oscillator to 17 mcs., and, feeding through a S.W. dummy aerial, screw T11 right up and then unscrew until the first peak is heard. Then adjust T12 and then T13 for maximum. Remove jig.

Calibration.—Switch receiver to M.W. band, set oscillator to 370 metres (811 kcs.), tune in spot on receiver. Adjust the wavelength dial pointer by means of the knurled screw so that the pointer reads 370 metres.

Exact replacement condensers available from A. H. Hunt, Ltd., Garratt Lane, Wandsworth, London, S.W.18, for the 650A are: For CL 4233, 7s.; C2, 2989, 7s. 6d.; C24, 4232, 6s. 6d.; and for C46, 2918, 1s. 9d.

RESISTANCES

| R. | Purpose. | Ohms. |
|----|-----------------------------------|-----------|
| 1 | V1 A.V.C. feed | 800,000 |
| 2 | V1 cathode bias | 409 |
| 6 | V2 series grid | 32 |
| 7 | V2 A.V.C. feed | 800,000 |
| 8 | V2 screen potr. (part) | 50,000 |
| 9 | V2 screen potr. (part) | 32,000 |
| 10 | V1 screen and V2 anode decoupling | 8,000 |
| 11 | V2 cathode bias (part) | 500 |
| 12 | Osc. grid leak | 50,000 |
| 13 | A.V.C. decoupling | 1.25 meg. |
| 14 | V2 cathode bias (part) | 20,000 |
| 15 | V2 cathode potr. (part) | 160 |
| 17 | V3 cathode bias | 320 |
| 18 | V3 screen feed and load (gram) | 50,000 |
| 20 | Pick-up shunt | 500,000 |
| 21 | H.F. stopper | 50,000 |
| 22 | Volume control | 350,000 |
| 24 | T.I. potr. (part) | 5 meg. |
| 25 | T.I. potr. (part) | 640,000 |
| 26 | P.I. anode feed | 2 meg. |
| 27 | A.V.C. diode load | 640,000 |
| 28 | V4 grid leak | 1 meg. |
| 29 | V4 grid stopper | 1,000 |
| 30 | V4 cathode bias (part) | 160 |
| 31 | V4 cathode bias (part) | 200 |
| 32 | Tone modifier | 100 |
| 33 | Tone control | 50,000 |
| 34 | Osc. grid | 50 |
| 35 | Osc. anode feed M.W. and L.W. | 2,000 |
| 36 | Tone modifier | 50,000 |
| 37 | V1 anode decoupling | 2,000 |

CONDENSERS

| C. | Purpose. | Mfds. |
|----|-----------------------------------|---------|
| 1 | H.T. smoothing | 25 |
| 2 | H.T. smoothing | 32 |
| 17 | L.W. aerial fixed trimmer | .00008 |
| 18 | V1 grid isolating | .0001 |
| 19 | V1 cathode bias shunt | .1 |
| 21 | V2 grid coupling | .0001 |
| 22 | V2 cathode bias shunt | .1 |
| 23 | V2 screen decoupling | .1 |
| 24 | V1 screen and V2 anode decoupling | 32 |
| 25 | Osc. grid | .00005 |
| 26 | S.W. osc. fixed padder | .0045 |
| 27 | M.W. osc. fixed padder | .0004 |
| 28 | A.V.C. line decoupling | .1 |
| 29 | I.F.T1 prim. fixed trimmer | .0001 |
| 30 | I.F.T1 sec. fixed trimmer | .0001 |
| 31 | T.I. grid decoupling | .05 |
| 32 | V3 cathode bias shunt | .05 |
| 33 | I.F.T2 prim. fixed trimmer | .000103 |
| 34 | I.F.T2 sec. fixed trimmer | .000103 |
| 35 | A.V.C. diode coupling | .00008 |
| 36 | H.F. bypass | .00005 |
| 37 | 'Gram. L.F. coupling | .05 |
| 41 | L.F. coupling | .02 |
| 42 | Tone control | .05 |
| 43 | M.W. anode extra coupling | .000002 |
| 44 | M.W. anode fixed trimmer | .000064 |
| 45 | L.W. anode fixed trimmer | .00025 |
| 46 | V4 cathode bias shunt | 25 |
| 47 | Pentode compensator | .002 |
| 48 | L.W. osc. fixed trimmer | .00004 |
| 49 | V1 anode decoupling | .05 |
| 50 | Tone compensation | .05 |

